



PHASE SHIFTING DIFFERENTIAL TRANSMISSIONS

APPLICATIONS

The Specon PSD line of phase shifting differential transmissions offers an extremely reliable, inherently simple and precise method for the correction of register or adjustment of phase. A development of the Specon mechanical transmission product line, they can readily be applied to shaft driven equipment. Service proven Specon differential assemblies are used in the PSD units.

The ease of adjustment, precision of correction attainable and rapidity of response permit use of the Specon PSD units in automated machinery. They can be used with photo-electric position sensing equipment - as is often done where pre-printed stock must be cut off or with any compatible feed-back system.

Precision gears are used throughout, keeping backlash to a minimum, well within operating limits customarily associated with high quality transmission gearing.

SOME TYPICAL APPLICATIONS ARE:

- Conveyor drives • Printing presses • Paper converting machinery • Textile machinery • Paper and other web cut-off machines • Plastic web or film machinery • Packaging machinery • Speed corrector

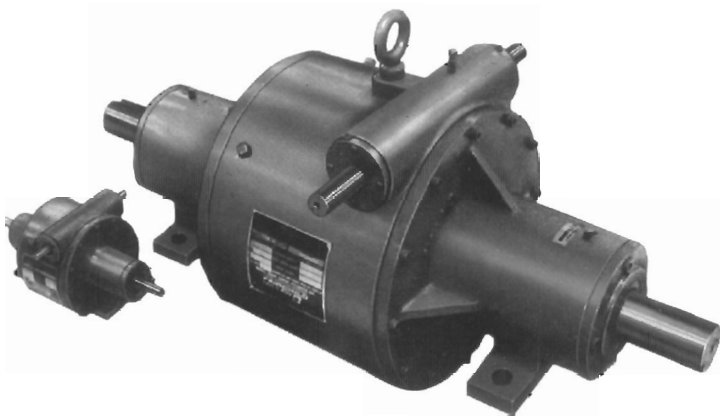

FEATURES

- # Unlimited correction in either direction.
- # In-line arrangement of the 1:1 LPSD.
- # High ratio between correction shaft and output shaft.
- # Low correction shaft torque requirement.
- # Input-output shaft bearing span.
- # Splash lubrication, integral sump.

BENEFITS

- # Eliminates the necessity of resetting.
- # Permits splitting of existing line shaft to accommodate PSD unit. Input and output shafts have same diameter.
- # Gives extremely fine adjustment.
- # Facilitates low power manual or electrical adjustment.
- # Permits high overhung loads.
- # Needs minimum of service or attention.

SPECIFICATIONS

CAPACITIES AND RATINGS

PSD

Shafts may be operated in either direction. Spider Shaft and Side Gear Shaft rotate in the same direction, and either may be the input shaft. The ratio between the Spider Shaft and the Side Gear Shaft is 2:1 with no correction applied.

Both shafts of the PSD unit rotate in the same direction, and either may be used as the input to obtain a 2:1 speed increase or decrease. Rotation may be in either direction. Wide-span shaft mounting accommodates high overhung loads.

Use of the spider shaft as the input gives an inherent 2:1 speed step-up input to output. Conversely, using the side gear shaft as the input results in an inherent 2:1 speed reduction. When the spider shaft is the input, each full turn of the correction shaft changes phase relationship by 3.6 degrees. When the side gear shaft is the input, each turn of the correction shaft results in a 1.8° change in phase relationship. (See Nomograph)

Correction is unlimited in either direction and can be applied while the equipment is running or while it is stopped. Correcting torque is low; therefore the correction shaft may be operated manually or by motor. Once made, the correction is "locked in."

2:1 PSD CORRECTION RATIO*			
Model No. Suffix	Worm Gear Ratio	Correction Shaft Spider Shaft	Correction Shaft Side Gear Shaft
— 100	100:1	200:1	100:1
— 50	50:1	100:1	50:1
—25	25:1	50:1	25:1

*When ordering, add the suffix to the selected model No., to identify the required correction ratio. The 100:1 worm gear ratio (—100) is standard and if no suffix number is identified, this ratio will be supplied.

Note: The 100:1 correction ratio tends to be self-locking, but correction shaft should be held stationary to prevent drift. The 25:1 and 50:1 correction ratios will back-drive and correction shaft must be held stationary.

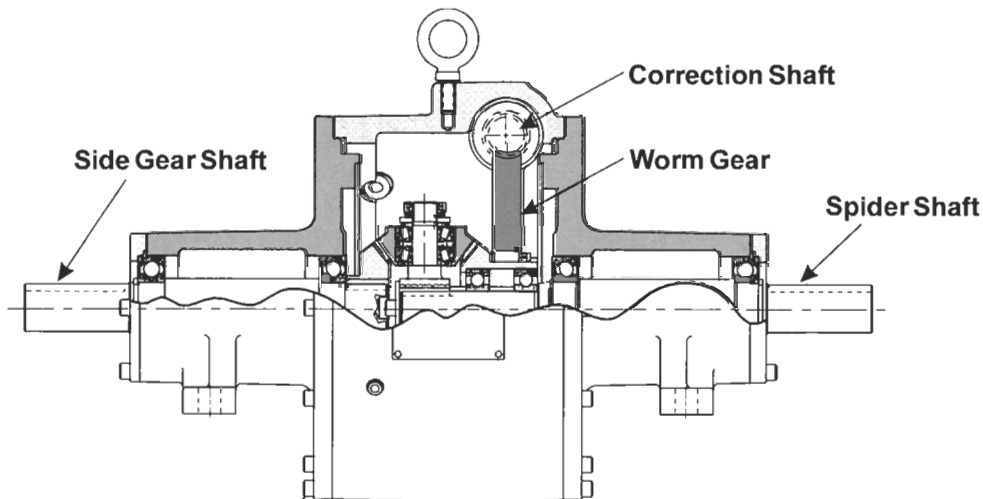

2:1 PSD Cross Section View

Correction is made by a worm gear fastened rigidly to one of the differential assembly side gears. A worm on the correction shaft drives the combined worm gear and side gear element to introduce a relative speed change between the input and output shafts of the transmission and thereby change their phase relationship. (See Nomographs)

The high ratio of 100:1 between the correction shaft and the worm gear, permits extremely fine adjustments to be made with ease. At the same time, phase corrections of considerable magnitude can be accomplished speedily since the low torque needed by the correction shaft permits it to be turned rapidly with a low power correction motor.

SPEED AND PHASE NOMOGRAPH

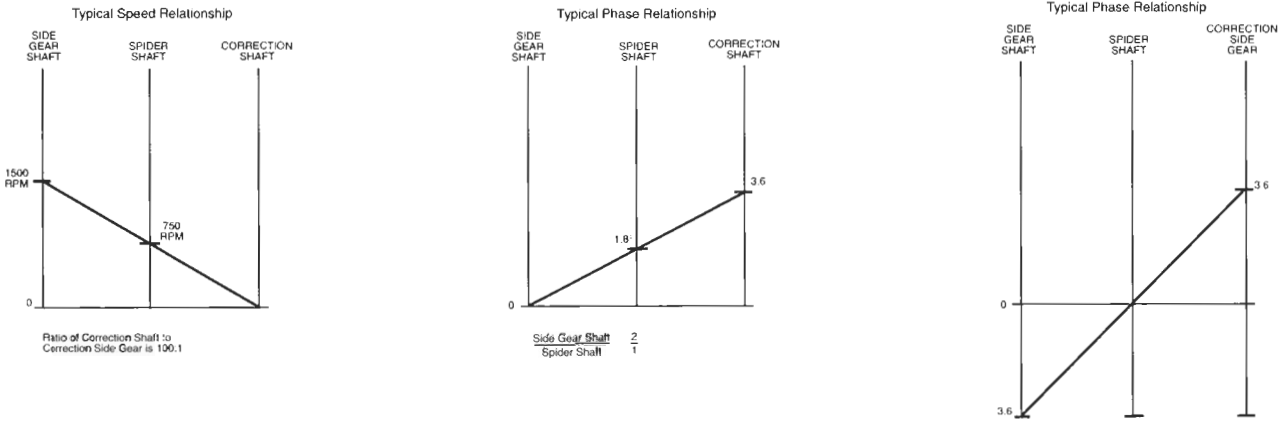

SPEED CORRECTOR

The Specon PSD transmission can also be used as a speed correcting device for accurately trimming line shaft speed. If the correction shaft is continuously driven by a variable speed element, the output shaft will be adjustable in speed as a function of the correction shaft speed.

Because of the ratio of the worm gear set, a speed change of 10:1 at the correction shaft from the variable speed element would produce approximately a 1% speed change at the output shaft. Thus, when a load change causes a speed variation in the variable speed element, the net variation at the output shaft would be only 1/100 of that speed variation. And so accurate control of output speed with the rigidity of fixed gearing would be attained.

The accompanying nomograph shows the speed relationship of the differential elements with an input speed of 1500 RPM to the side gear shaft and 1800-180 RPM at the correction shaft. Of course the correction shaft can be rotated in either direction to trim outside speed above or below nominal value. The nomograph shows the results of this change in direction. In this instance an inherent input to output reduction occurs. If inherent input to output ratio is required to be increasing, the

spider shaft could be used as the input and similar result occurs. This relationship is also shown on the accompanying nomographs.

A review of the speed, torque and power relationship of the differential as outlined in Specon Bulletin No. 204 will indicate that only 1/100 of the power transmitted through the PSD transmission is required at the correction shaft. Because of the efficiency of the worm gear correction and other practical considerations, the element used at the correction shaft should have about 1/50 of the capacity of the PSD unit selected.

The preceding analysis deals with the standard unit which has a 100:1 ratio worm gear set. By utilizing double and quadruple lead worms it is possible to incorporate a 50:1 or 25:1 ratio at the correction input. This reduction in ratio results in an increase in output speed trim range for the same amount of adjustment range of the variable element. Accuracy would also be reduced by this change and power required at the correction shaft would increase. Although accuracy is affected by this change, even with the 25:1 ratio worm gear set, fine and accurate control of speed is still attained.

SPEED CORRECTION NOMOGRAPH

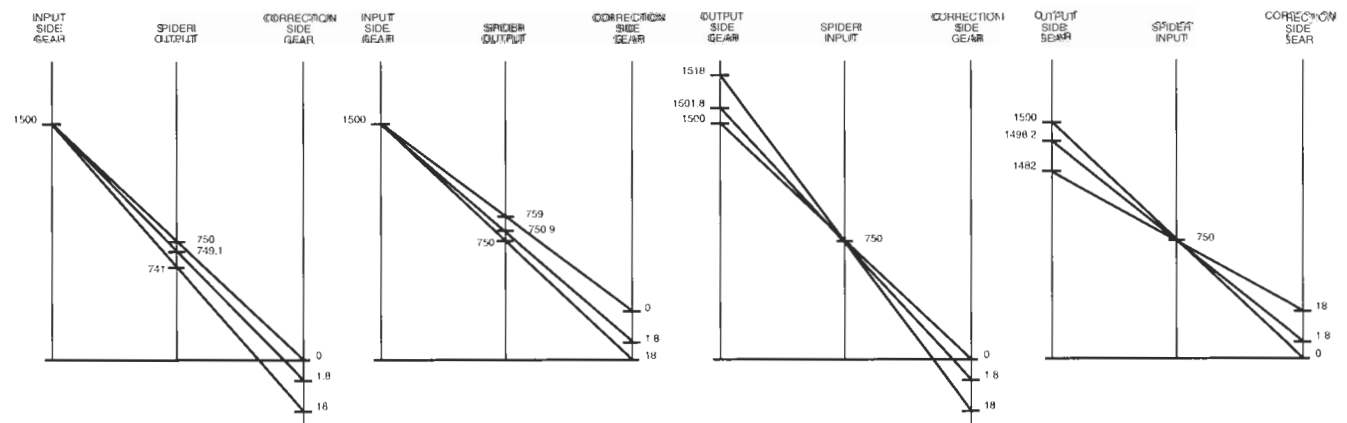

HORSEPOWER NOMOGRAPH – Rt. Angle Option

(PSD ONLY)

The accompanying nomograph shows the input speed and horsepower relationship for the right angle drive options (see page 14) connected to the Side gear shaft

and the spider shaft of the phase shifting differential unit.

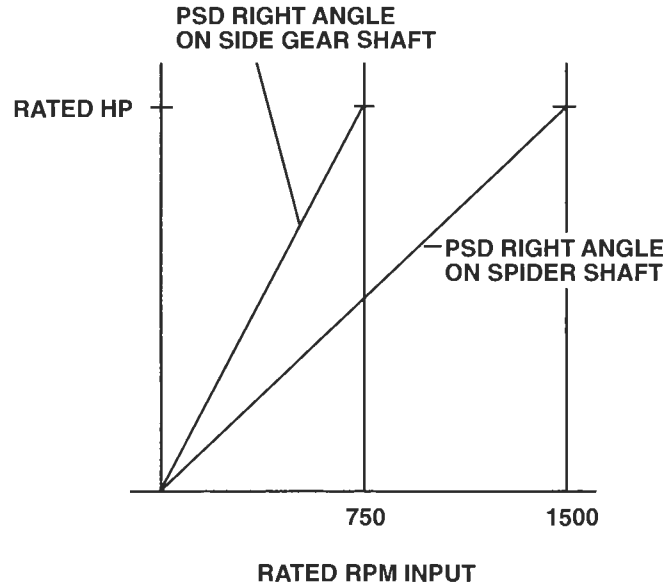

LPSD CAPACITIES AND RATINGS

Both shafts of the LPSD unit rotate in the same direction and either shaft may be used as the input shaft to obtain a 1:1 ratio. Rotation may be in either direction.

Since the input/output relationship is 1:1 with zero correction applied, an existing line shaft may be cut and the transmission added with standard couplings at both the input and output shafts.

One revolution of the correction shaft will rotate the output shaft 10.8° . Correction ratio is 33.3:1 so thirty three and one third turns of the correction shaft will rotate the output shaft through one revolution. If the X shaft (See Typical Phase Relationship) is at 0° , the Y

shaft will be at (-3) times the correction worm gear, since with a 100:1 worm gear ratio, one turn of the correction shaft equals 3.6° . If the Y shaft is at 0° , the X shaft will be at (3) times the correction shaft.

Correction is unlimited in either direction and can be applied while the equipment is running or while it is stopped. Correction may be applied manually or electrically through an integrally mounted correction motor.

Correction is made by a worm gear fastened rigidly to a movable internal gear, within which rotate three needle bearing mounted planet gears.

CORRECTION RATIO*		
Model No. Suffix	Worm Gear Ratio	Correction Shaft Output Shaft
— 33	100:1	$33\frac{1}{3}:1$
— 16	50:1	$16\frac{2}{3}:1$
— 8	25:1	$8\frac{1}{3}:1$

NOTE:

Omission of suffix on order will be assumed to indicate that standard 100:1 worm gear ratio and 33.33:1 correction shaft/output shaft ratio is required.

Shafts may be operated in either direction. Input/Output Shafts rotate in the same direction, and at a 1:1 ratio with no correction applied.

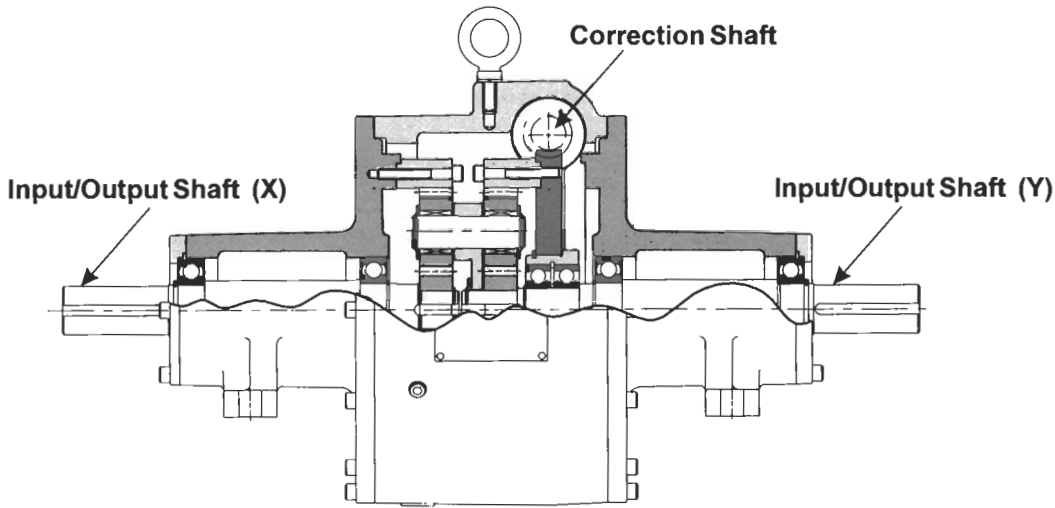

1:1 LPSD Cross Section View

SPEED AND PHASE NOMOGRAPH (33¹/₃:1 correction ratio)

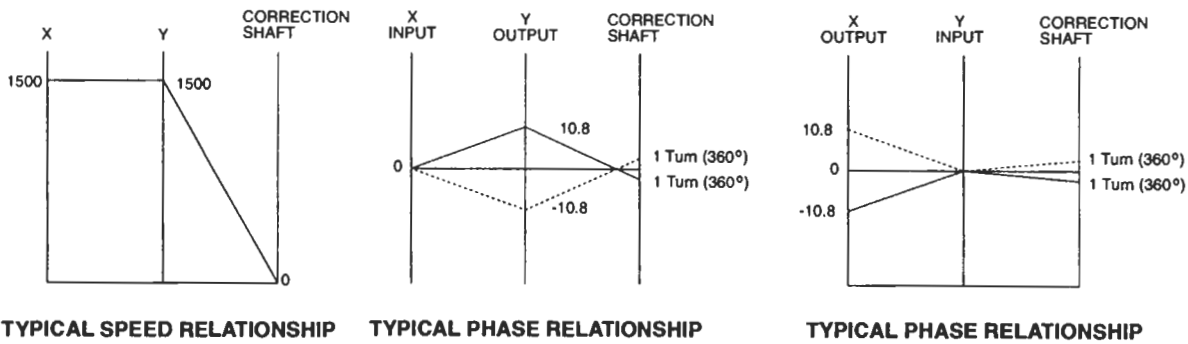

SPEED CORRECTOR

The Specon LPSD transmission can also be used as a speed correcting device for accurately trimming line shaft speed. If the correction shaft is continuously driven by a variable speed element, the output shaft will be adjustable in speed as a function of the correction shaft speed.

The accompanying nomograph shows the speed relationship of the different elements with an input speed of 1500 rpm to the input shaft and 600-60 rpm at the correction shaft. The correction shaft can be rotated in either direction to trim output speed above or below normal value. The nomograph shows the results of the change in direction.

SPEED CORRECTION NOMOGRAPH (33¹/₃:1 correction ratio)

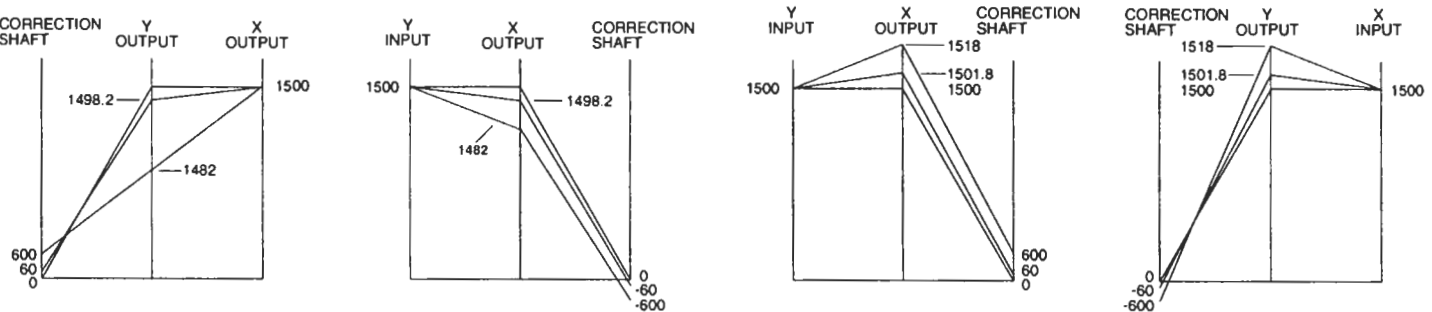

NOT TO SCALE

Both shafts of the FPSD unit rotate in the same direction and either shaft may be used as the input shaft to obtain a 1:1 ratio. Rotation may be in either direction.

Since the input/output relationship is 1:1 with zero correction applied, an existing line shaft may be cut and the transmission may be added with standard couplings at both the input and output shafts.

The standard correction ratio offered is $33\frac{1}{3}:1$. Correction ratios of $16\frac{2}{3}:1$ and $8\frac{1}{3}:1$ are available as options. For the standard correction ratio of $33\frac{1}{3}:1$, one turn of

the correction shaft will cause the output shaft to rotate 10.8 degrees ($360 \text{ degrees}/33.3333$). Refer to the speed and phase nomograph for relative rotation.

Correction is unlimited in either direction and can be applied while the equipment is running or while it is stopped. Correction may be applied manually or electrically. Electrical correction is applied by means of an integrally mounted correction motor.

FPSD CAPACITIES AND RATINGS

4:1 FPSD CORRECTION RATIO*			
Model No. Suffix	Worm Gear Ratio	Correction Shaft High Speed Shaft	Correction Shaft Low Speed Shaft
33	100:1	33.33:1	133.33:1
16	50:1	16.66:1	66.66:1
8	25:1	8.33:1	33.33:1

*When ordering, add the suffix to the selected model No., to identify the required correction ratio. The 100:1 worm gear ratio (-33) is standard and if no suffix number is identified, this ratio will be supplied.

Note: The 100:1 correction ratio tends to be self-locking, but correction shaft should be held stationary to prevent drift. The 25:1 and 50:1 correction ratios will back-drive and correction shaft must be held stationary.

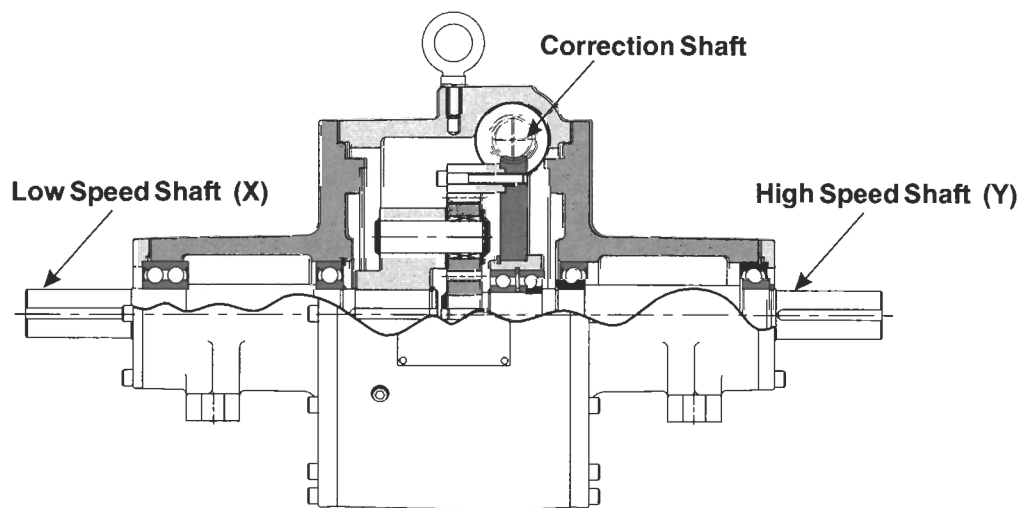

4:1 FPSD Cross Section View

SPEED AND PHASE NOMOGRAPH (33¹/₃:1 Correction Ratio)

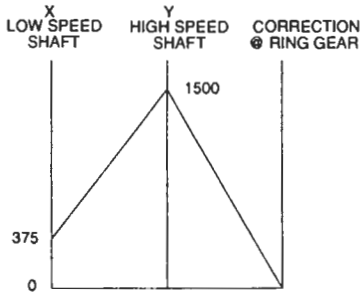

TYPICAL SPEED RELATIONSHIP

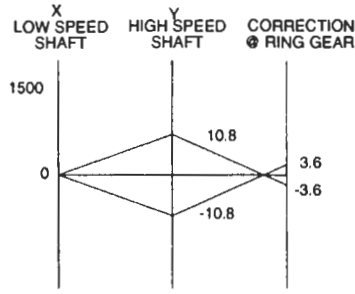

TYPICAL PHASE RELATIONSHIP

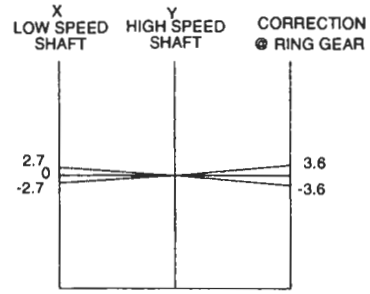

TYPICAL PHASE RELATIONSHIP

The accompanying nomograph shows the speed relationship of the different elements with an input speed of 1500 RPM to the high speed shaft (Y) and 600-60 RPM at the correction shaft. The correction shaft can

be rotated in either direction to trim output speed above or below normal value. The nomograph shows results of the change in direction.

SPEED CORRECTION NOMOGRAPHS (33¹/₃:1 Correction Ratio)

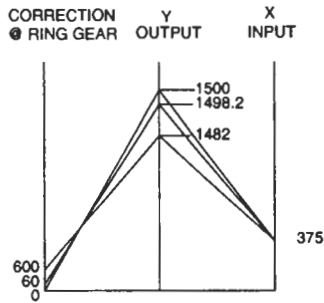

NOT TO SCALE

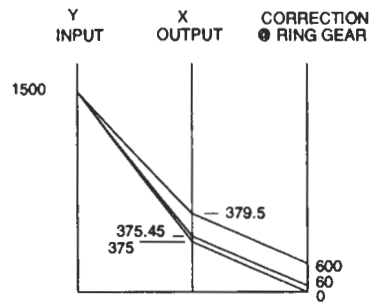
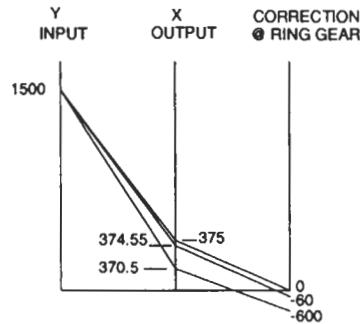

NOT TO SCALE

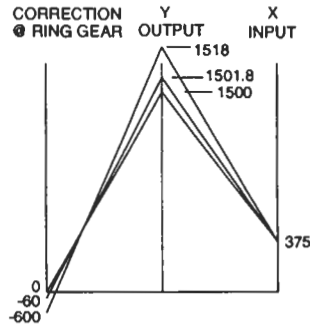

Both power shafts of the FPSD unit rotate in the same direction at a 4:1 ratio. Either shaft may be used as the input shaft and the rotation may be in either direction.

speed shaft to rotate 2.7 degrees (10.8 degrees/4). Refer to the speed and phase nomograph for relative rotation.

The standard correction ratio offered is 33¹/₃:1. Correction ratios of 16²/₃:1 and 8¹/₃:1 are available as options. For the standard correction ratio of 33¹/₃:1, one turn of the correction shaft will cause the high speed shaft to rotate 10.8 degrees (360 degrees/33.3333 or the low

Correction is unlimited in either direction and can be applied while the equipment is running or while it is stopped. Correction may be applied manually or electrically. Electrical correction is applied through an integrally mounted correction motor.

OUTLINE DIMENSIONS

2:1 PSD, 1:1 LPSD and FPSD

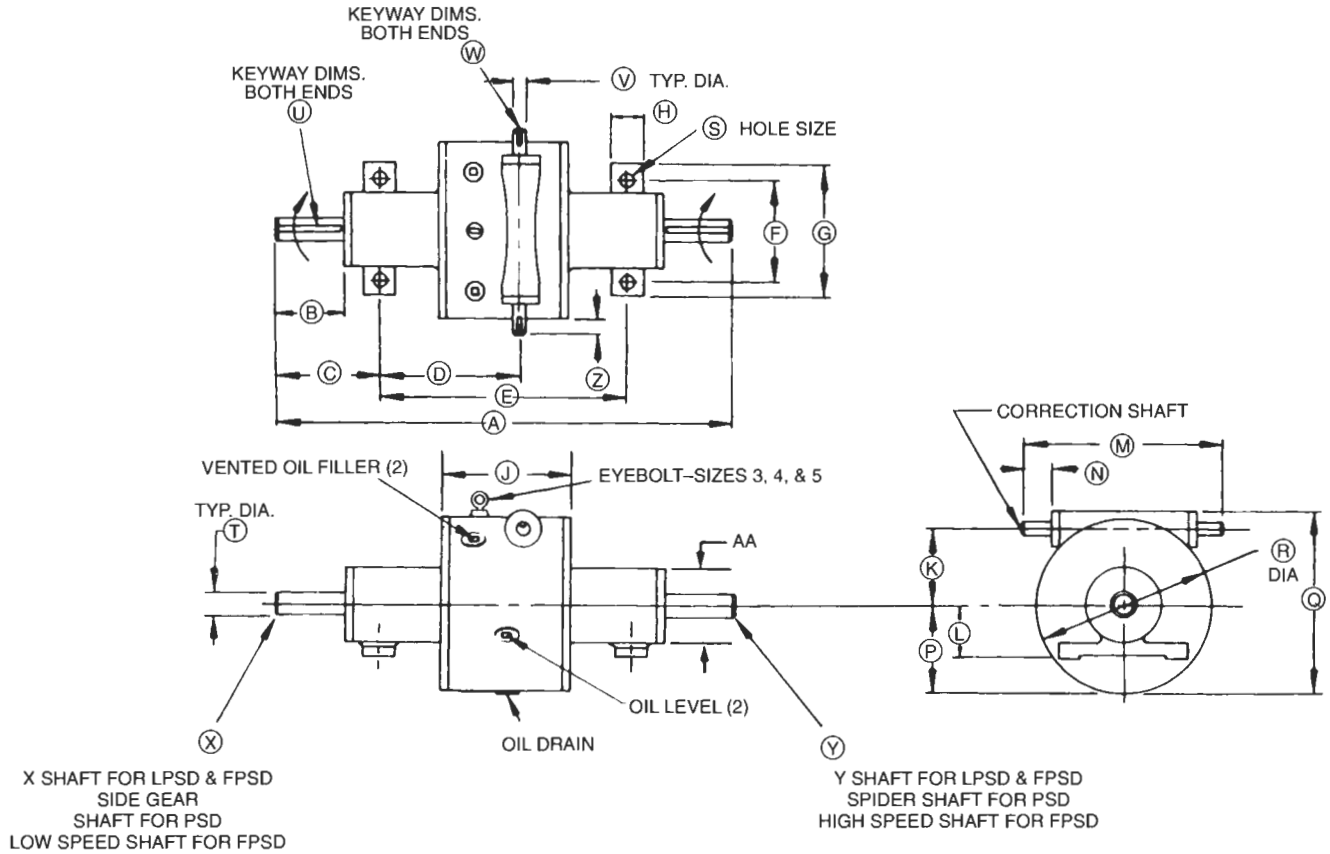

DIMENSION TABLE — 2:1 PSD, 1:1 LPSD & 4:1 FPSD

Size	A	B	C	D	E	F	G	H	J	K	L	M	N	P	Q	R	S	T	U	V	W	Z	AA
00	12 ³ / ₈	1 ³ / ₄	2 ¹⁵ / ₁₆	4 ¹ / ₃₂	6 ¹ / ₂	3	4	1	3 ⁷ / ₈	2.333	1 ⁵ / ₈	6 ³ / ₄	7 ⁷ / ₈	2 ³ / ₄	5 ⁷ / ₈	5 ¹ / ₂	1 ³ / ₃₂	9 ¹ / ₁₆	1 ¹ / ₈ X 1 ¹ / ₁₆ X 1 ⁵ / ₈	3 ¹ / ₈	3 ¹ / ₃₂ X 3 ¹ / ₆₄ X 3 ¹ / ₄	5 ¹ / ₈	2 ¹ / ₄
0	18	2 ¹ / ₂	4 ¹ / ₈	6 ¹ / ₁₆	9 ³ / ₄	3 ³ / ₄	5	1 ¹ / ₄	5 ³ / ₈	3.437	2 ¹ / ₁₆	9 ⁷ / ₈	1 ¹ / ₄	4	8 ¹ / ₂	8	1 ⁷ / ₃₂	3 ¹ / ₄	3 ¹ / ₁₆ X 3 ¹ / ₃₂ X 2 ³ / ₈	1 ¹ / ₂	1 ¹ / ₈ X 1 ¹ / ₁₆ X 1 ¹ / ₈	1 ⁵ / ₁₆	2 ⁷ / ₈
1	20	2 ¹ / ₂	4 ³ / ₈	7	11 ¹ / ₄	4 ¹ / ₂	5 ³ / ₄	1 ¹ / ₄	6 ³ / ₈	4.075	2 ¹ / ₂	11 ³ / ₈	1 ³ / ₄	4 ¹ / ₂	9 ³ / ₄	9	1 ⁷ / ₃₂	1 ¹ / ₈	1 ¹ / ₄ X 1 ¹ / ₈ X 2 ³ / ₈	5 ¹ / ₈	3 ¹ / ₁₆ X 3 ¹ / ₃₂ X 1 ⁵ / ₈	1 ³ / ₁₆	3 ¹ / ₂
3	25	3	5 ³ / ₈	8 ³ / ₄	14 ¹ / ₄	5 ¹ / ₄	6 ³ / ₄	2	7 ³ / ₈	4.667	2 ⁷ / ₈	13 ¹ / ₂	2 ¹ / ₈	5 ¹ / ₄	11 ³ / ₈	10 ¹ / ₂	1 ¹ / ₁₆	1 ³ / ₈	5 ¹ / ₁₆ X 5 ¹ / ₃₂ X 2 ⁷ / ₈	3 ¹ / ₄	3 ¹ / ₁₆ X 3 ¹ / ₃₂ X 2	1 ¹ / ₂	4 ¹ / ₄
4	32	3 ¹ / ₂	7	11 ⁵ / ₁₆	18	6 ⁷ / ₈	8 ¹ / ₂	2 ¹ / ₄	9 ¹ / ₄	5.625	3 ⁵ / ₈	15 ⁵ / ₈	2 ¹ / ₄	6 ⁷ / ₁₆	13 ¹³ / ₁₆	12 ⁷ / ₈	1 ⁹ / ₁₆	1 ⁹ / ₁₆	3 ¹ / ₈ X 3 ¹ / ₁₆ X 3 ¹ / ₄	7 ¹ / ₈	1 ¹ / ₄ X 1 ¹ / ₈ X 2 ¹ / ₈	1 ⁷ / ₁₆	5 ¹ / ₈
5	36	4	8	12 ⁷ / ₈	20	7 ¹ / ₄	9 ¹ / ₂	2 ¹ / ₂	10 ³ / ₄	5.625	3 ³ / ₄	16 ¹ / ₈	2 ¹ / ₂	6 ⁷ / ₁₆	13 ¹³ / ₁₆	12 ⁷ / ₈	1 ⁵ / ₁₆	1 ³ / ₄	3 ¹ / ₈ X 3 ¹ / ₁₆ X 3 ³ / ₄	1	1 ¹ / ₄ X 1 ¹ / ₈ X 2 ³ / ₈	1 ⁵ / ₈	5 ¹ / ₂
7	40	4 ¹ / ₂	9	14 ⁹ / ₁₆	22	8 ¹ / ₂	10 ³ / ₄	2 ³ / ₄	12 ¹ / ₂	7.000	4 ¹ / ₄	18 ¹ / ₂	3	7 ⁵ / ₈	16 ¹ / ₂	15 ¹ / ₄	2 ¹ / ₂	2 ¹ / ₂	5 ¹ / ₈ X 5 ¹ / ₁₆ X 4 ¹ / ₄	1 ¹ / ₈	1 ¹ / ₄ X 1 ¹ / ₈ X 2 ³ / ₈	1 ⁵ / ₈	6 ⁷ / ₈
8	66 ¹ / ₂	6 ¹ / ₂	20 ¹ / ₂	22 ¹ / ₈	25 ¹ / ₂	20	23	3	28 ¹ / ₂	9.375	10 ³ / ₄	23 ¹ / ₂	3 ¹ / ₂	10	21 ⁵ / ₈	20	1 ³ / ₁₆	3 ¹ / ₄	7 ¹ / ₈ X 7 ¹ / ₁₆ X 6 ³ / ₄	1 ¹ / ₄	1 ¹ / ₄ X 1 ¹ / ₈ X 3 ³ / ₈	1 ³ / ₄	8

Tolerance on shaft diameters: Nominal + .0000, -.0005

RIGHT ANGLE DRIVE ASSEMBLY

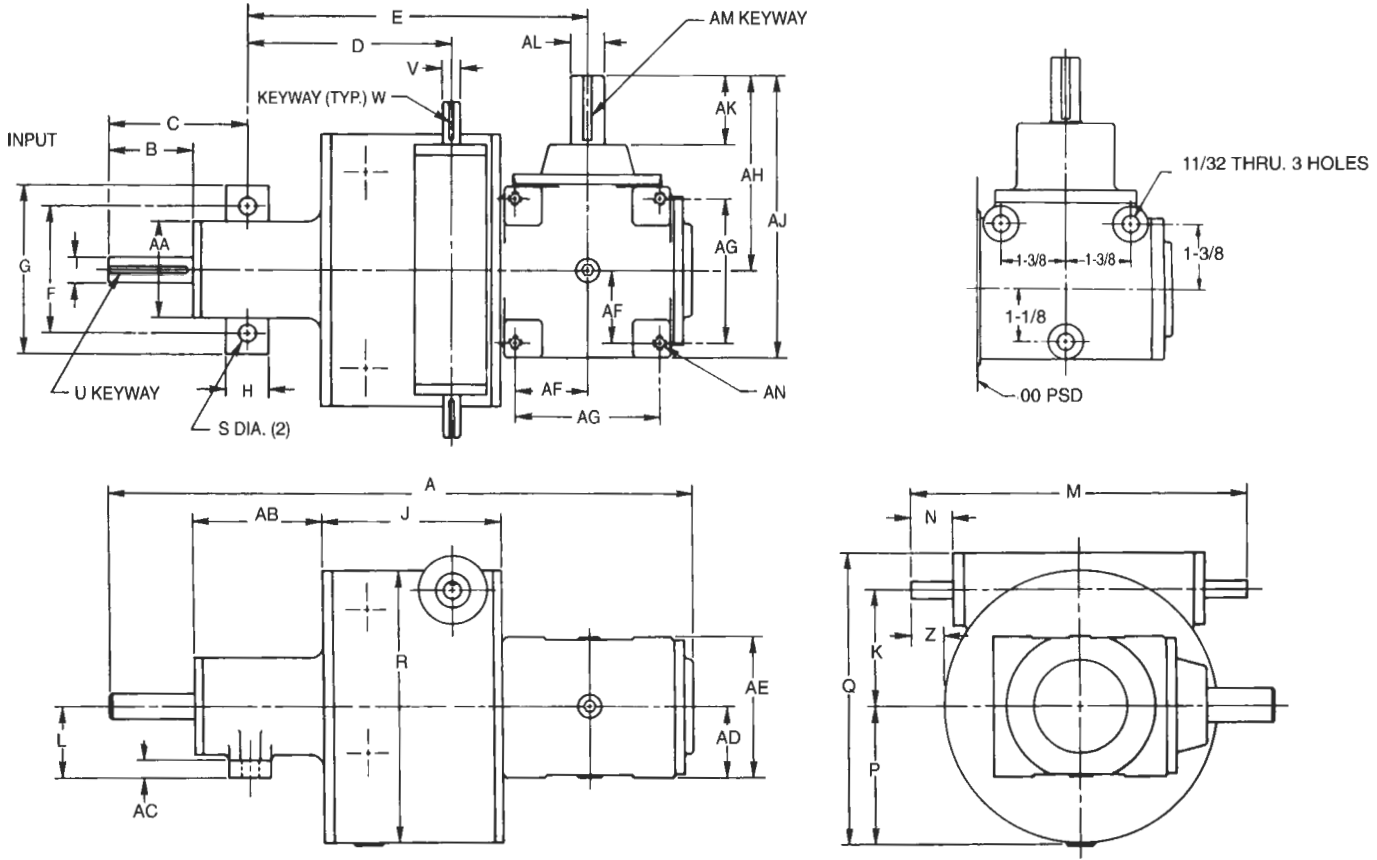

DIMENSION TABLES RIGHT ANGLE ASSEMBLIES

Size	A	B	C	D	E	F	G	H	J	K	L	M	N	P	Q	R	S	T	U	V	W
00	12 ¹ / ₄	1 ³ / ₈	2 ¹⁵ / ₁₆	4 ¹ / ₃₂	7 ¹ / ₁₆	3	4	1	3 ⁷ / ₈	2.333	1 ⁵ / ₈	6 ³ / ₄	7 ⁷ / ₈	2 ³ / ₄	5 ⁷ / ₈	5 ¹ / ₂	1 ³ / ₃₂	9 ¹ / ₁₆	1 ⁵ / ₈ X 1 ¹ / ₁₆ X 1 ⁵ / ₈	3 ⁵ / ₈	3 ³ / ₃₂ X 3 ⁷ / ₆₄ X 3 ¹ / ₄
0	17 ⁹ / ₃₂	2 ¹ / ₂	4 ¹ / ₈	6 ¹ / ₁₆	10 ¹ / ₁₆	3 ³ / ₄	5	1 ¹ / ₄	5 ⁹ / ₁₆	3.437	2 ¹ / ₁₆	9 ⁷ / ₈	1 ¹ / ₄	4	8 ¹ / ₂	8	1 ⁷ / ₃₂	3 ¹ / ₄	3 ¹ / ₁₆ X 3 ³ / ₃₂ X 2 ³ / ₈	1 ¹ / ₂	1 ¹ / ₈ X 1 ¹ / ₁₆ X 1 ¹ / ₈
1	19 ³ / ₄	2 ¹ / ₂	4 ³ / ₈	6 ³¹ / ₃₂	11 ³ / ₄	4 ¹ / ₂	5 ³ / ₄	1 ¹ / ₄	6 ¹ / ₄	4.071	2 ¹ / ₂	11 ³ / ₈	1 ³ / ₄	4 ¹ / ₂	9 ³ / ₄	9	1 ⁷ / ₃₂	1 ¹ / ₈	1 ¹ / ₄ X 1 ¹ / ₈ X 2 ³ / ₈	5 ⁵ / ₈	3 ¹ / ₁₆ X 3 ³ / ₃₂ X 1 ⁵ / ₈
3	25 ⁵ / ₈	3	5 ³ / ₈	8 ³ / ₄	14 ¹³ / ₁₆	5 ¹ / ₄	6 ³ / ₄	2	7 ³ / ₁₆	4.667	2 ⁷ / ₈	13 ¹ / ₂	2 ¹ / ₈	5 ¹ / ₄	11 ³ / ₈	10 ¹ / ₂	1 ¹ / ₁₆	1 ³ / ₈	5 ¹ / ₁₆ X 5 ⁵ / ₃₂ X 2 ⁷ / ₈	3 ¹ / ₄	3 ¹ / ₁₆ X 3 ³ / ₃₂ X 2
4	29 ¹³ / ₁₆	3 ¹ / ₂	7	11 ⁵ / ₁₆	17 ³ / ₄	6 ⁷ / ₈	8 ¹ / ₂	2 ¹ / ₄	9 ³ / ₁₆	5.625	3 ⁵ / ₈	15 ⁵ / ₈	2 ¹ / ₄	6 ⁷ / ₁₆	13 ¹¹ / ₁₆	12 ⁷ / ₈	1 ³ / ₁₆	1 ⁹ / ₁₆	3 ³ / ₈ X 3 ¹ / ₁₆ X 3 ¹ / ₄	7 ⁷ / ₈	1 ¹ / ₄ X 1 ¹ / ₈ X 2 ¹ / ₈
5	32 ² / ₁₆	4	8	12 ⁷ / ₈	19 ¹ / ₂	7 ¹ / ₄	9 ¹ / ₂	2 ¹ / ₂	10 ¹¹ / ₁₆	5.625	3 ³ / ₄	16 ¹ / ₈	2 ¹ / ₂	6 ⁷ / ₁₆	13 ¹³ / ₁₆	12 ⁷ / ₈	1 ⁵ / ₁₆	1 ³ / ₄	3 ³ / ₈ X 3 ¹ / ₁₆ X 3 ³ / ₄	1	1 ¹ / ₄ X 1 ¹ / ₈ X 2 ³ / ₈
7	38 ¹ / ₂	4 ¹ / ₂	9	14 ⁹ / ₁₆	22 ³ / ₄	8 ¹ / ₂	10 ³ / ₄	2 ³ / ₄	12 ¹ / ₂	7.000	4 ¹ / ₄	18 ¹ / ₂	3	7 ⁵ / ₈	16 ¹ / ₂	15 ¹ / ₄	1 ¹ / ₁₆	2 ¹ / ₂	1 ¹ / ₂ X 1 ¹ / ₄ X 4 ¹ / ₄	1 ¹ / ₈	1 ¹ / ₄ X 1 ¹ / ₈ X 2 ³ / ₈

Size	Z	AA	AB	AC	AD	AE	AF	AG	AH	AJ	AK	AL	AM	AN (TOP & BOTTOM)
00	5 ⁵ / ₈	2 ¹ / ₄	2 ¹ / ₂	3 ³ / ₈	1 ¹⁹ / ₃₂	3 ³ / ₁₆	-	-	4 ⁷ / ₈	6 ³ / ₈	1 ³ / ₈	⁶²⁵ / ₆₂₄	3 ¹ / ₁₆ X 3 ³ / ₃₂ X 1 ¹ / ₁₆	1 ¹¹ / ₃₂ THRU. 3 HOLES
0	1 ¹⁵ / ₁₆	2 ⁷ / ₈	3 ¹³ / ₁₆	1 ¹ / ₂	2 ¹ / ₁₆	4 ¹ / ₈	2 ¹ / ₈	4 ¹ / ₄	5 ²³ / ₃₂	8 ⁹ / ₃₂	2	^{1.0005} / ₉₉₉₅	1 ¹ / ₄ X 1 ¹ / ₈ X 1 ¹⁷ / ₃₂	3 ³ / ₈ - 16NC X 1 ¹¹ / ₁₆ DEEP (4)
1	1 ³ / ₁₆	3 ¹ / ₂	4 ¹¹ / ₃₂	5 ⁵ / ₈	2 ¹³ / ₁₆	5 ⁵ / ₈	2 ¹ / ₄	4 ¹ / ₂	8 ¹⁵ / ₃₂	11 ¹³ / ₃₂	2 ¹ / ₂	^{1.2515} / _{1.2505}	1 ¹ / ₄ X 1 ¹ / ₈ X 1 ²⁹ / ₃₂	1 ¹ / ₂ - 13NC X 1 ¹³ / ₁₆ DEEP (4)
3	1 ¹ / ₂	4 ¹ / ₄	5 ²⁷ / ₃₂	5 ⁵ / ₈	4 ³ / ₃₂	8 ³ / ₁₆	3 ¹ / ₄	6 ¹ / ₂	10 ⁷ / ₈	14 ²³ / ₃₂	3	^{1.3765} / _{1.3755}	5 ¹ / ₁₆ X 5 ⁵ / ₃₂ X 2 ⁵ / ₁₆	1 ¹ / ₂ - 13NC X 1 DEEP (4)
4	1 ⁷ / ₁₆	5 ¹ / ₈	7 ⁷ / ₈	3 ¹ / ₄	4 ³ / ₃₂	8 ³ / ₁₆	3 ¹ / ₄	6 ¹ / ₂	11 ¹⁵ / ₃₂	15 ⁵ / ₁₆	3	^{1.500} / _{1.498}	3 ³ / ₈ X 3 ¹ / ₁₆ X 2 ¹ / ₄	1 ¹ / ₂ - 13NC X 3 ³ / ₄ DEEP (4)
5	1 ⁵ / ₈	5 ¹ / ₂	8 ⁵ / ₈	3 ³ / ₄	4 ³ / ₃₂	8 ³ / ₁₆	3 ¹ / ₄	6 ¹ / ₂	11 ¹⁵ / ₃₂	15 ⁵ / ₁₆	3	^{1.500} / _{1.498}	3 ³ / ₈ X 3 ¹ / ₁₆ X 2 ¹ / ₄	1 ¹ / ₂ - 13NC X 3 ³ / ₄ DEEP (4)
7	1 ³ / ₄	6 ⁷ / ₈	9 ¹ / ₄	1	4 ³ / ₄	9 ¹ / ₂	4	8	15	19 ³ / ₄	4	^{2.000} / _{1.998}	1 ¹ / ₂ X 1 ¹ / ₄ X 3 ³ / ₄	1 ¹ / ₂ - 13NC X 3 ³ / ₄ DEEP (4)

PRINCIPLES OF OPERATION

Phase Shifting Differentials make use of several different gear drive systems to accomplish adjustment of input and output shaft relationships.

BEVEL GEAR DRIVE

Any bevel gear differential consists of three elements: a spider carrying one or more freely running bevel pinions, and two bevel side gears which mesh with the spider pinions. The spider shaft and both of the side gears can absorb or deliver power.

Spider speed is the algebraic average of the two side gear speeds.

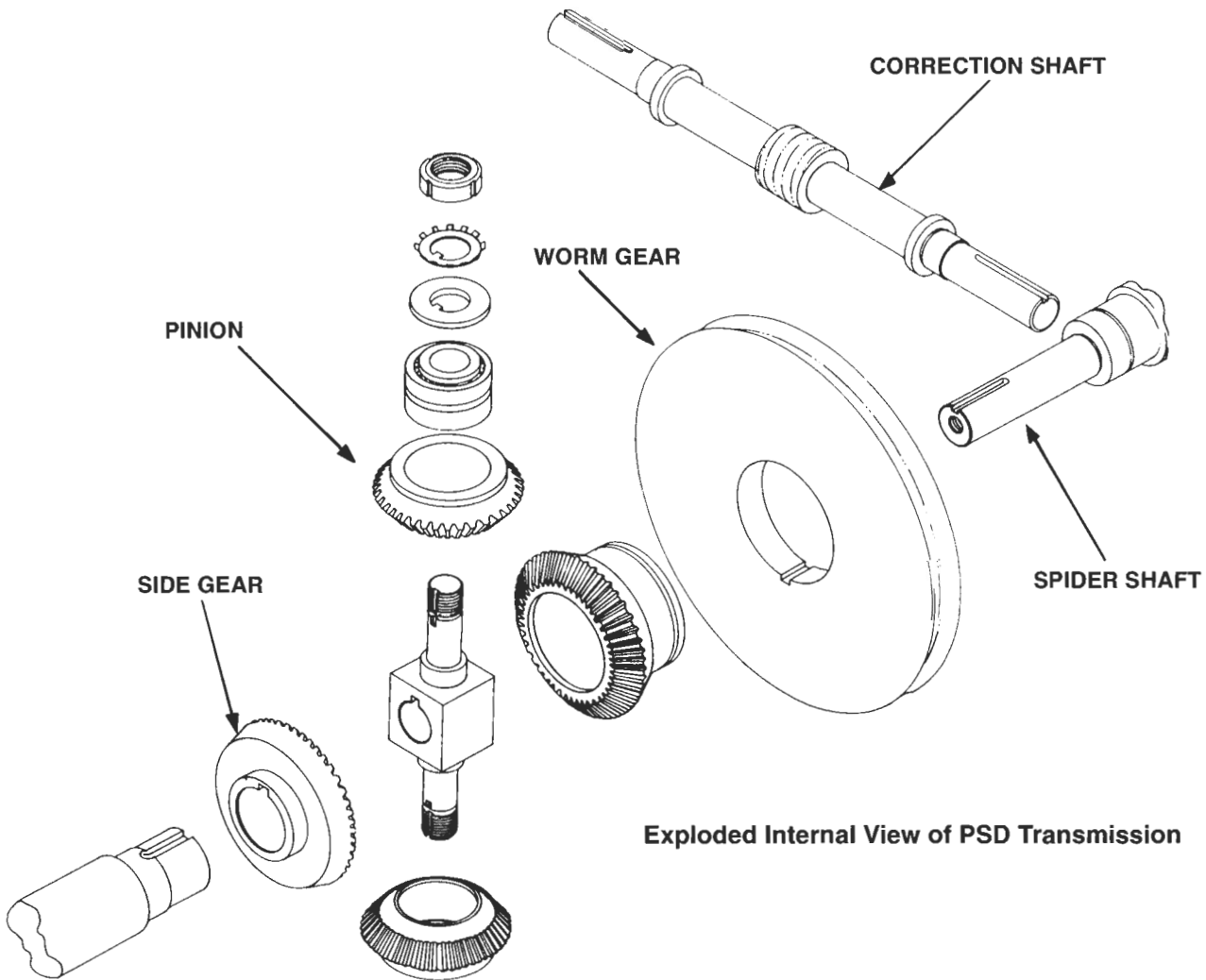
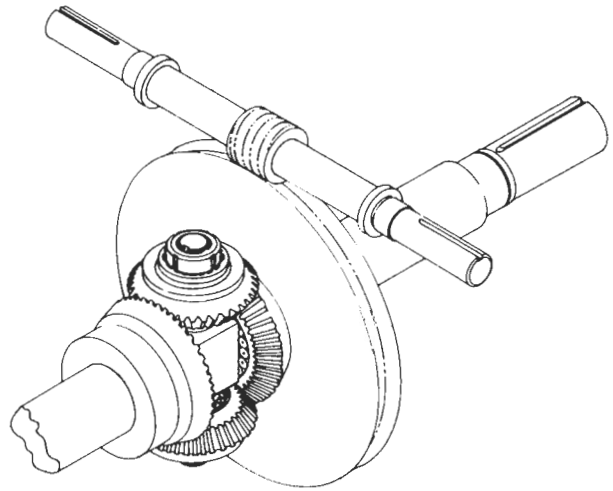

Exploded Internal View of PSD Transmission

In a bevel gear differential unit, either the spider shaft or the side gear shaft can be used as the input. In the Fairchild bevel gear PSD a 2:1 speed increase or reduction is achieved dependent on which shaft is used as the input.

PLANETARY GEAR DRIVE

Internal (ring) gears — Ring gears produce an output rotation that is in the same direction as the input. As the name implies, teeth are cut on the inside surface of a cylindrical ring, inside of which are mounted a single or set of exterior-tooth spur gears: typically consisting of three or four larger spur gears (planets) surrounding a smaller central pinion (sun).

Normally, the ring gear is stationary, causing the planets to orbit the sun in the same rotational direction as that of the sun.

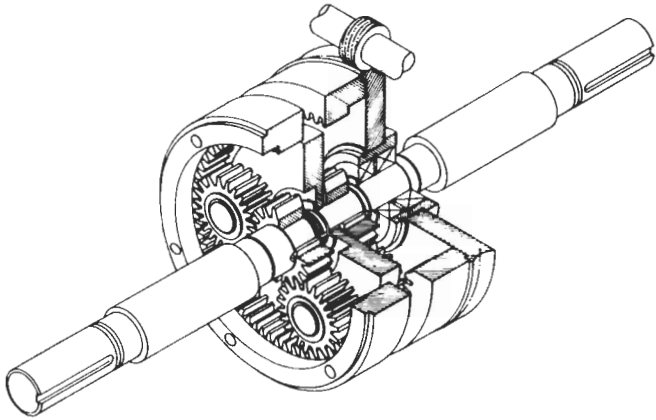

In the Fairchild LPSD, two planetary drives with a common carrier are mounted back to back. The fixed internal (ring) gear and the movable internal (ring) gear are stationary. Planet gear motion from either shaft used as input is transmitted through the carrier to the other set of planet gears, and subsequently to the central pinion (sun) of the other shaft. Ratios of pinion to carrier in the transmission path are shown below.

For this reason, this type of assembly is often referred to as a planetary system. The orbiting motion of the planets is transmitted to the output shaft by a planet carrier.

Both shafts of the planetary gear PSD rotate in the same direction and either shaft can be used as input or output. In the Fairchild planetary gear LPSD a 1:1 ratio is achieved which permits splitting an existing line shaft to accommodate the LSPD.

For both these gear designs, phase changes are made by turning the correction shaft which rotates the worm gear attached to a movable internal gear.

This action introduces a relative rotational component to the normal rotation of the gear drive, displacing one shaft relative to the other. Correction can be made in either direction and can be made while the PSD is operating or idle.

If the correction shaft is driven continuously, the output shaft will vary in speed as a function of correction shaft speed. This allows continuous TRIMMING of line shaft speed.

$$\frac{A}{B} = \frac{4}{1} \quad \frac{B}{C} = \frac{1}{4}$$

$$\frac{A}{B} \times \frac{B}{C} = 1:1$$

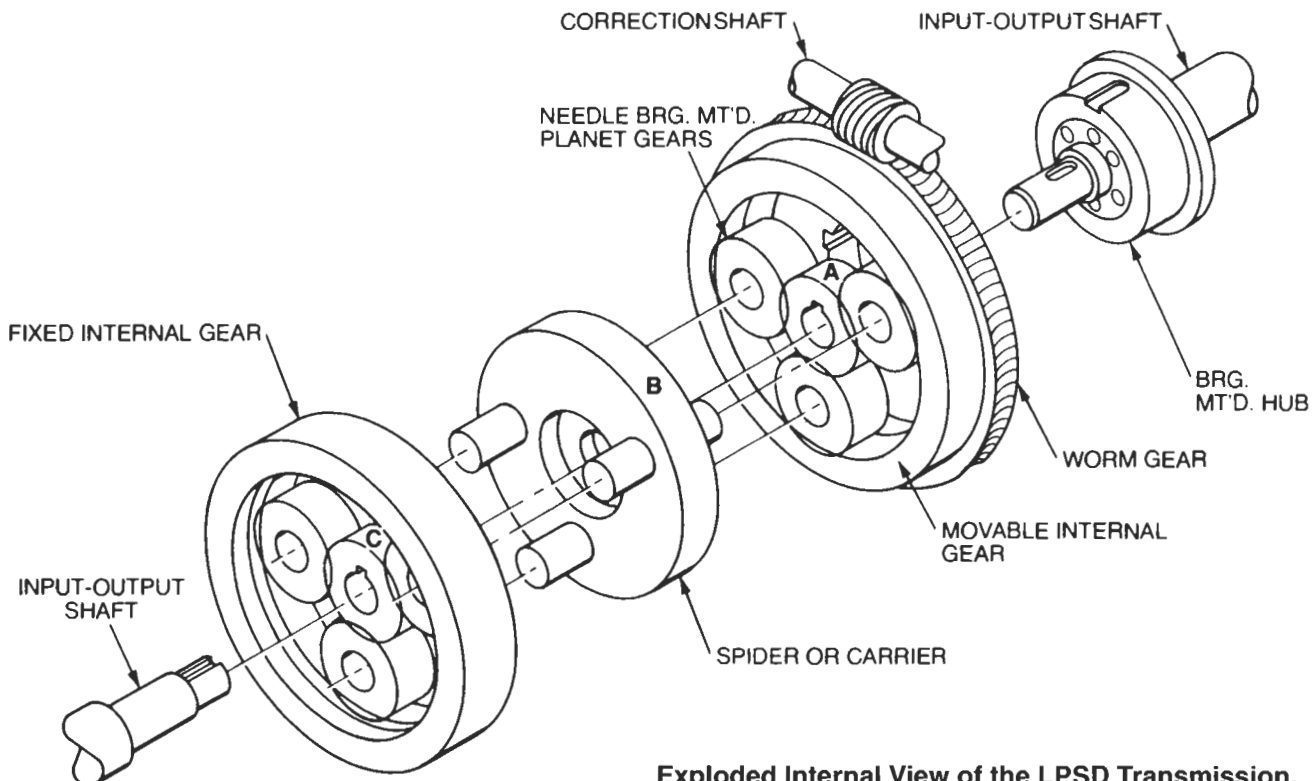

Exploded Internal View of the LPSD Transmission.

In the Fairchild FPSD, the movable internal (ring) gear is stationary. Planet gear motion from the High Speed shaft used as input is transmitted to the spider gear of the Low Speed shaft.

Spider motion of the Low Speed shaft used as an input is transmitted through the planetary gears to the High Speed shaft.

Ratios of pinion to carrier in the transmission path are:

$$A/B = 4/1 \quad B/A = 1/4$$

Both shafts of the planetary gear of the FPSD rotate in the same direction and either shaft can be used as an input depending on whether the requirement is a reduction or increase in speed.

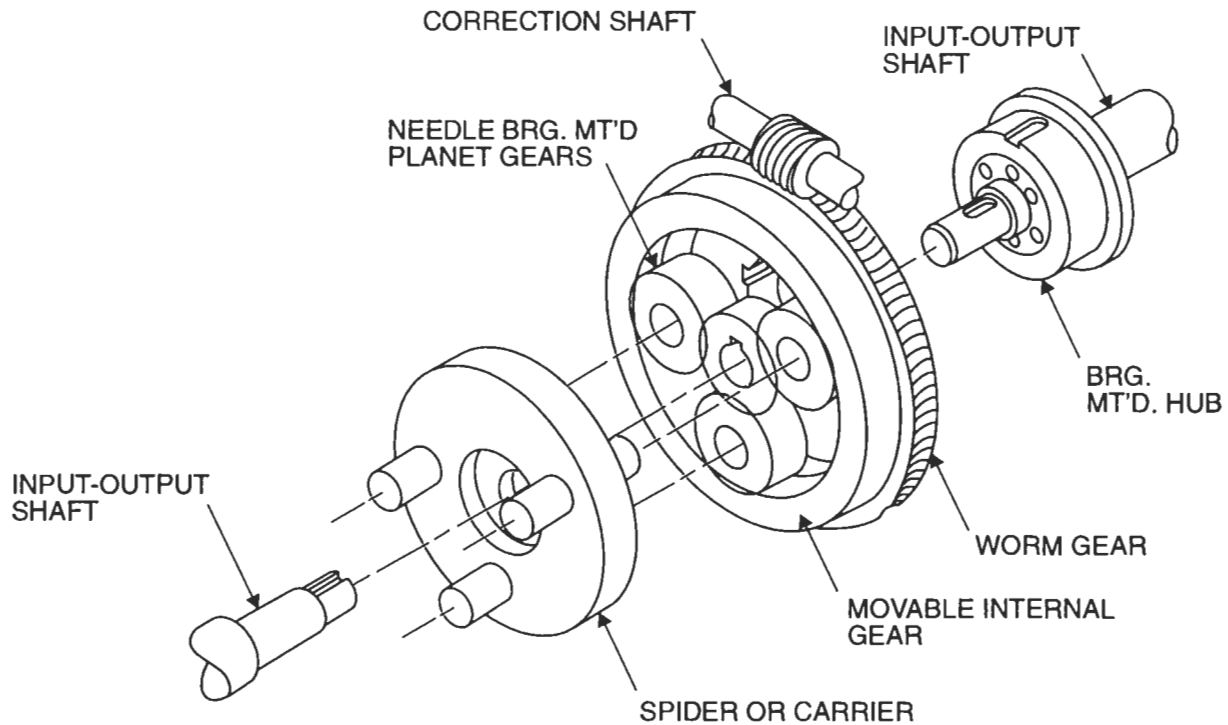

Exploded Internal View of the FPSD Transmission

Phase changes are made by turning the Correction shaft which rotates the worm gear attached to a movable internal gear.

This action introduces a relative rotational component to the normal rotation of the gear drive, displacing one shaft relative to the other. Correction can be made in either direction and can be made while the FPSD is operating or idle.

SELECTION

TRANSMISSION SELECTION

The basic speed, torque and power relationships of the various elements of the bevel differential are expressed by the following statements. The spider speed is always equal to the algebraic sum of the two side gear speeds divided by two. Spider torque is equal to the sum of the torque of each side gear. The side gear torques are equal. The bevel gear differential must also follow the law of conservation of energy — that is, power in is equal to power out. A more detailed analysis of these characteristics is presented in Specon Bulletin Number 204. Because of this constant torque relationship between the differential side gears and spider, these units and assemblies are rated at the spider. Thus, if these ratings are not exceeded, all other differential gearing will be within design capacity. All listed ratings carry a service factor of 1.0. In selecting a Specon PSD transmission, the speed and torque requirements of the driven machine should first be fixed in order to determine the nominal power requirement. Considering the character of the load and duty factor, determine the service factor from the following table.

Operating Hours Per Day	Nature of Load	Service Factor
8-10	Uniform	1.0
8-10	Moderate	1.25
8-10	Heavy	1.75
10-24	Uniform	1.25
10-24	Moderate	1.5
10-24	Heavy	2.0

Multiply the previously determined nominal power requirement by the appropriate service factor and determine the required power rating of the Specon PSD transmission. For example, if the driven machine demands 14 HP and is operated 8-10 hours per day under heavy shock load conditions, the service factor would be 1.75 and the required power rating would be 25 HP. Thus, a number 4 PSD transmission should be specified. Either the spider shaft or side gear shaft may be used as the input with a resulting inherent 2:1 speed increase or 2:1 reduction. Select the input shaft which will best suit the application. The speed to the spider shaft should not exceed the nominal spider shaft speeds shown in the rating table.

1:1 LPSD RATING TABLE

Nominal H.P.	Model No.	Torque Capacity (lb. in.)	Max RPM	Max RPM (Correction Shaft)	Correction Shaft Torque Requirement (lb. in.)
1.5	00LPSD	55	1800	600	6
3.5	0LPSD	150	1500	600	15
6.5	1LPSD	275	1500	600	26
12	3LPSD	500	1500	600	45
25	4LPSD	1050	1500	600	93
40	5LPSD	1680	1500	600	150
75	7LPSD	3150	1500	600	300

2:1 PSD RATING TABLE

Nominal HP.	Model No.	Weight Lb.	†Torque Capacity		Max RPM			Correction Shaft* Torque Requirement		
			Spider Shaft	Side Gear Shaft	Spider Shaft	Side Gear Shaft	Correction Shaft	Model # Suffix		
								-100	-50	-25
1.5	00PSD	19	110	55	900	1800	1800	2	2.5	4
3.5	0PSD	47	300	150	750	1500	1800	5	6	10
6.5	1PSD	70	550	275	750	1500	1800	8.5	12	17
12	3PSD	127	1000	500	750	1500	1800	15	20	30
25	4PSD	235	2100	1050	750	1500	1800	31	42	62
40	5PSD	300	3360	1680	750	1500	1800	50	65	100
75	7PSD	534	6300	3150	750	1500	1800	100	130	200
125	8PSD	1600	13100	6550	600	1200	1800	200	X	X

† lb. in.

* Correction shaft torque requirement value is a direct percentage of power shaft torque

4-1 FPSD RATING TABLE

Nominal H.P.	Model No.	Torque Capacity		Max. RPM		Correction Shaft Torque Requirement @600 RPM Max.
		High* Speed Shaft	Low Speed Shaft	High Speed Shaft	Low Speed Shaft	
1.5	00FPSD	55	220	1800	450	6
3.5	0FPSD	150	600	1500	375	15
6.5	1FPSD	275	1100	1500	375	26
12	3FPSD	500	2000	1500	375	45
25	4FPSD	1050	4200	1500	375	93
40	5FPSD	1680	6720	1500	375	150
75	7FPSD	3150	12,600	1500	600	300

*See 4:1 FPSD cross section view on page 6 for Shaft Designations

RIGHT ANGLE DRIVE OPTION

Any phase shifting differential can be equipped with a right angle drive for applications where shaft configurations require 90 degree mounting of a transmission unit.

Assemblies include single shaft horizontal, double shaft horizontal, single shaft vertical and double shaft vertical outputs.

Output shafts may be configured to the right or left, up

or down, at either the spider or side gear ends or at both ends of the phase shifting differential.

A 1:1 ratio, either opposite or of the same rotational relation can be accomplished using either the PSD or LPSD. If a 33.3:1 correction ratio is required, the LPSD must be used. For the LPSD, the configurations described above can be accomplished at either the X or the Y shaft.

Right Angle Drive Assembly Arrangements.

NOTE: Consult factory for availability and dimensions of assemblies AA, BB, CC and DD.

Standard Right Angle Ratios
 1:1, 1.5:1, 2:1, 1:1.5, 1:2

ORDERING INFORMATION

When Ordering Specify:	For Standard Unit	For RA Unit
Select Size, Rating	Page 8, 13 & 14	Page 9 & 14
Correction Ratio	Page 2, 4 & 6	Page 2, 4 & 6
Right Angle Assembly Arrangement, If Required	—	Page 11
Overall Ratio, Expressed As Input @ PSD (RPM) Output @ RA (RPM)	PSD 2/1) LPSD 1/1) Page 8 FPSD 4/1)	Page 8 x GB Ratio Page 14
Electric Remote Control Motor Characteristics Voltage, Frequency, Correction Rate @ Output, Etc.	Consult Factory For Appropriate Outline Drawing & Dimensions	
Examples:	1PSD-100 3LPSD-33	RA1PSD-100 Assembly A 2/1 RA3LPSD-33 Assembly B 1/2

SERVICE INFORMATION

A list of replacement parts and instructions for servicing the Phase Shifting Differential Transmission are available in the Installation, Operating and Maintenance Instructions Bulletin 205 IOM.

<p>FAIRCHILD INDUSTRIAL PRODUCTS COMPANY 3920 WEST POINT BLVD. • WINSTON-SALEM, NC 27103-6708 • USA TELEPHONE 336/659-3400 1-800-334-8422 FAX 336/659-9323 FOR TOTAL CONTROL WHEN THE POWER'S ON</p>		<p>MECHANICAL & ELECTRO - MECHANICAL POWER TRANSMISSION EQUIPMENT</p> 
--	---	--



FM NO. 25571